



# INDUSTRIAL DUTY

## Engine Driven High Pressure Pumps

- **Cast Iron and Aluminum Construction**
- **Dual Volute Design on Single Stage Models**
- **Buna-N Mechanical Seal and O-Ring**
- **Optional Viton® Mechanical Seal & O-Ring Available on Single Stage Models**
- **Single and Two Stage Models Available**
- **1-1/2" and 2" NPT Port Size**
- **Self-Priming\***
- **Stainless Steel Closed Impellers on 396/478 Series Models**
- **Aluminum Closed Impellers on 583 Series Models**
- **Engine Options: Honda or Briggs & Stratton Gasoline or Yanmar Diesel**
- **Pumps Include Heavy Duty Steel Roll Frame**
- **Wheel Kits Available with Semi-Pneumatic or Pneumatic Wheels**

\* Requires Foot Valve Above 10ft.



**1.5" High Pressure Pumps with Wheel Kit A734-90**

The AMT line of Engine Driven High Pressure pumps is designed for lawn sprinkling, agricultural spraying, dewatering, fire fighting, emergency water supply and pressure boosting. Single stage models feature replaceable Cast Iron dual volutes and stainless steel high efficiency closed impellers. Two-stage models feature Cast Iron diffusers and closed impellers for high efficiency producing up to 155 PSI that generally requires 8 horsepower or more from a single stage pump. Pumps offer a broad selection of gasoline engines from the leading engine manufacturers with dependable service worldwide. All models include Cast Iron pipe nipples and rugged steel roll frame for protection and durability.

AMT Engine Driven High Pressure pumps are reliable, cost effective and low maintenance. Many are readily available "Off-the-Shelf" for fast 24 hour shipment. For use with non-flammable liquids which are compatible with pump component materials.

Viton® is a registered trademark of E.I. DuPont



**1.5" 2 Stage High Pressure Pumps**

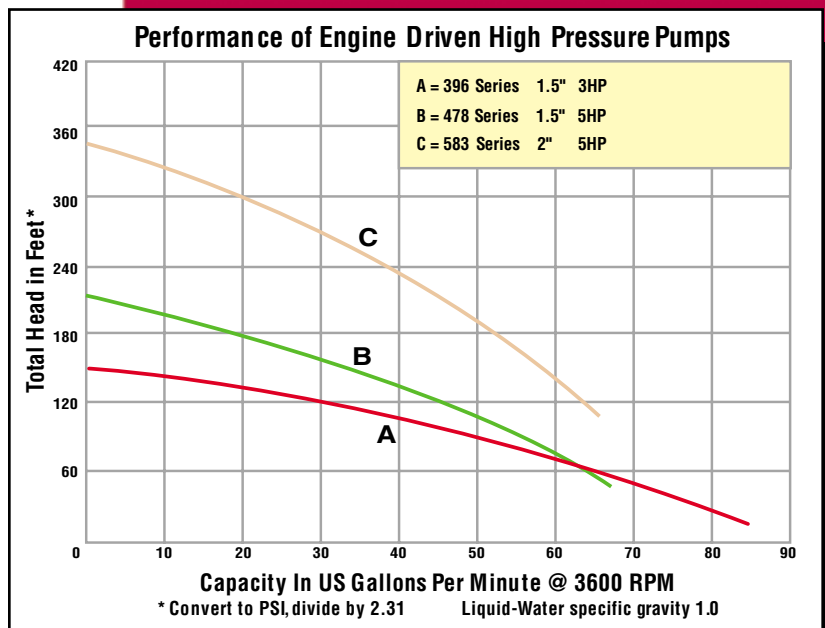

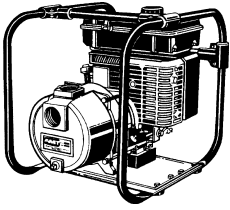

## 1-1/2" High Pressure Pumps (Single Stage)

Model#	Driver	Ship Wt.	Run Time	Tank Size
3960-95	B&S 525	50 Lbs.	180 Min.	3 Qt.

Cast Iron Construction with Stainless Steel Impellers

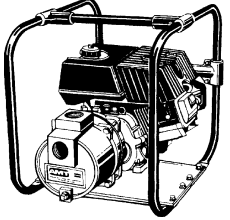

## 1-1/2" High Pressure Pumps (2 Stage)

Model#	Driver	Ship Wt.	Run Time	Tank Size
4787-95	B&S CP650	104 Lbs.	120 Min.	3 Qt.
4789-95	Honda GX160	99 Lbs.	100 Min.	3.8 Qt.

Cast Iron Construction with Stainless Steel Impellers

2 Stage Models Feature Oil Alert on Engines

\* Based on a Full Tank of Gas @ Maximum RPM (Approx.)

+ Overhead Valve Engine (OHV)

## 2" High Pressure Pumps (2 Stage)

Model#	Driver	Ship Wt.	Run Time	Tank Size
5830-96	B&S CP650	70 Lbs.	120 Min.	3 Qt.
5831-96	Honda GX160	66 Lbs.	100 Min.	3.8 Qt.
5830-D6	Yanmar Diesel L48	87 Lbs.	110 Min.	2.6 Qt.

Aluminum Construction

## Standard Features

- > Two NPT Pipe Nipples
- > Buna-N Mechanical Seal and O-Ring
- > Optional Viton® Mechanical Seal and O-Ring Available on Single Stage
- > Self-primers to 10 ft. w/o Foot Valve on 2 Stage Models
- > Replaceable Volute/Diffuser
- > Stainless Steel High Efficiency Closed Impellers on 396/478 Series
- > Maximum Temperature 180° F
- > Maximum Working Pressure 150 PSI
- > Single Stage Models Deliver up to 70 PSI and 4500 GPH
- > Two Stage Models Deliver up to 150 PSI and 5000 GPH
- > Optional Wheel Kits  
A734-90 10" Semi Pneumatic  
A735-90 16" Pneumatic

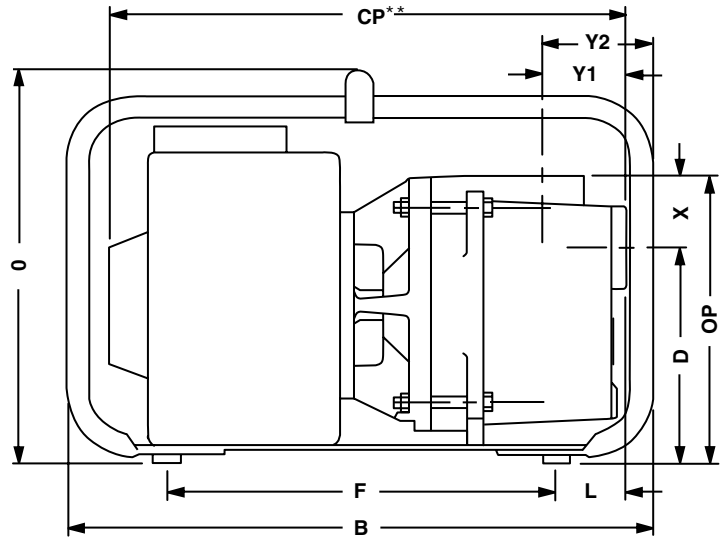
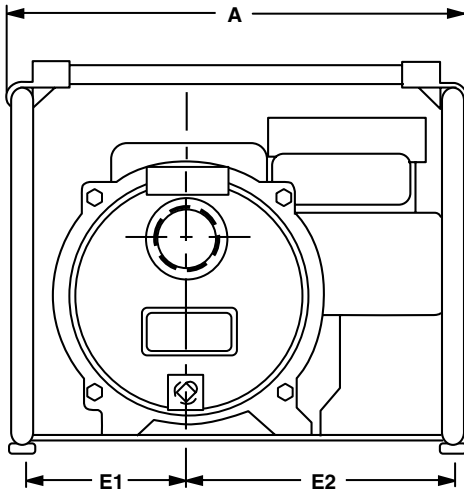

MODEL#	CURVE	HP Class++	A	B	CP**	D	E1	E2	F	L	O	OP	X	Y1	Y2
396 Series	A	3.5 HP	15.5	19.0	17.5	6.8	5.0	10.0	8.5	4.5	16.0	9.5	2.6	3.5	4.6
395 Series	B	5.5 HP	19.5	24.3	19.0	8.5	7.0	11.0	9.3	6.0	20.0	11.5	3.0	3.5	5.3
478 Series	C	5.5 HP	19.5	24.3	19.0	7.1	7.0	11.0	9.3	6.5	20.0	9.7	2.6	3.1	4.1
583 Series	D	5.5 HP	19.5	24.3	19.0	6.0	7.0	11.0	9.3	6.5	20.0	15	8	4	5

(++) HP Class represents market category and is not intended to define actual horsepower.

(\*\*) This dimension may vary due to engine manufacturer's specifications.

NOTE: Dimensions have a tolerance of ±1/8".

Viton® is a registered trademark of E.I. DuPont

See price book page 9

The Gorman-Rupp Company reserves the right to discontinue any model or change specifications at any time without incurring any obligation.

CP25-26 / 1006