

ENGINE-DRIVEN, SOLIDS-HANDLING TRASH PUMPS

Gorman-Rupp 3" engine-driven trash pumps are designed for applications that require high flow efficiency and solids-handling capability. Pumps are constructed of heavy-duty cast aluminum or cast iron with replaceable ductile iron impellers and steel or cast iron wearplates. Front cleanout design, on most models, permits easy removal of trash and debris without disconnecting hoses. Pumps are available with Honda gasoline or Hatz or Yanmar diesel engines. All models include a suction strainer and 90° discharge elbow.



Model: 13A52-GX390

Model: 13G1-GX160



Model: 13D-GX270



Model: 13E2-12LD477 S/G



FEATURES

- Cast aluminum or cast iron construction
- Viton®/silicon carbide-mechanical or Gorman-Rupp double-lubricated grease seals
- 3" NPT port sizes
- Engine options: Honda gasoline engine; Yanmar or Hatz diesel engine
- Heavy-duty steel roll cages
- Solids-handling to 2" (51 mm) diameter
- Suction strainer and 90° discharge elbow
- Self-priming up to 25 ft. (7,6 m) lift with built-in flap valve
- Replaceable ductile iron impeller and steel wearplate
- Maximum temperature to 160° F (71° C) (to 110° [43° C] for grease seal)
- Maximum operating pressure to 94 PSI (6,4 bar)
- Wheel kit available upon request

GENERAL INFORMATION

Model	Ship Wt. (Approx.)	Driver Type (HP)	Max. Solids	Suc. x Dis. (NPT)	Basic Construction	Seal Type & Elastomer/Faces	Tank Size	Run Time	Mounting
13A52-GX390	387 lbs.	Honda Gasoline	1-1/2" (38 mm)	3" x 3"	Cast Iron	Viton®* Silicon-Carbide	1.7 gal.	2.6 hrs.	Roll Cage
13D1-6X270	136 lbs.	Honda Gasoline	1-1/2" (38 mm)	3" x 3"	Aluminum	Viton®* Silicon-Carbide	1.6 gal.	2.7 hrs.	Roll Cage
13D-GX270	136 lbs.	Honda Gasoline	1-1/2" (38 mm)	3" x 3"	Aluminum	Gorman-Rupp Grease	1.6 gal.	2.7 hrs.	Roll Cage
13D1-L70EE	124 lbs.	Yanmar Diesel (6.7)	1-1/2" (38 mm)	3" x 3"	Aluminum	Viton®* Silicon-Carbide	0.92 gal.	2.2 hrs.	Roll Cage
13D-L70EE	124 lbs.	Yanmar Diesel (6.7)	1-1/2" (38 mm)	3" x 3"	Aluminum	Gorman-Rupp Grease	0.92 gal.	2.2 hrs.	Roll Cage
13D1-L70EE S/G*	144 lbs.	Yanmar Diesel (6.7)	1-1/2" (38 mm)	3" x 3"	Aluminum	Viton®* Silicon-Carbide	1.45 gal.	3.4 hrs.	Roll Cage
13D-L70EE S/G*	144 lbs.	Yanmar Diesel (6.7)	1-1/2" (38 mm)	3" x 3"	Aluminum	Gorman-Rupp Grease	1.45 gal.	3.4 hrs.	Roll Cage
13E2-12LD477 S/G*	655 lbs.	Kohler Diesel (15.5)	2" (51 mm)	3" x 3"	Cast Iron	Gorman-Rupp Grease	11.0 gal.	18.9 hrs.	Skid Base
13E52-GX390	363 lbs.	Honda Gasoline	2" (51 mm)	3" x 3"	Cast Iron	Viton®* Silicon-Carbide	1.7 gal.	1.9 hrs.	Roll Cage
13G1-6X160†	100 lbs.	Honda Gasoline	1-3/16" (30 mm)	3" x 3"†	Aluminum	Viton®* Silicon-Carbide	0.95 gal.	2.0 hrs.	Roll Cage
13G1-1B20†	121 lbs.	Hatz Diesel (4.7)	1-3/16" (30 mm)	3" x 3"†	Aluminum	Viton®* Silicon-Carbide	0.79 gal.	2.6 hrs.	Roll Cage

*12 volt electric start. Battery not included. †BSP flange kits available. *Viton® is a registered trademark of DuPont.

ENGINE-DRIVEN, SOLIDS-HANDLING TRASH PUMPS

10 SERIES

PERFORMANCE CURVES

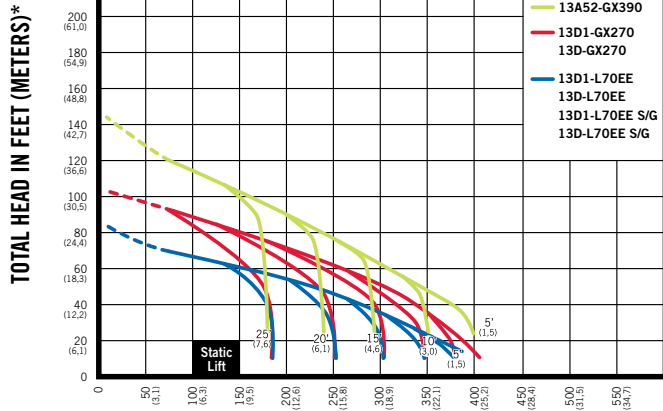

U.S. GALLONS PER MINUTE (LITERS PER SECOND)

Curves are based on a specific gravity of 1.0 *To convert to PSI divide by 2.31

PERFORMANCE CURVES

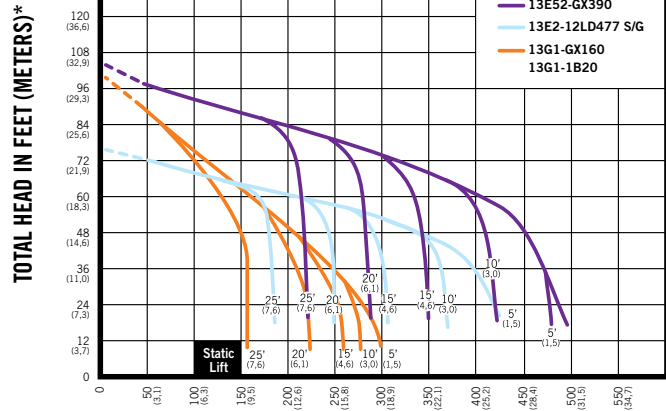

U.S. GALLONS PER MINUTE (LITERS PER SECOND)

Curves are based on a specific gravity of 1.0 *To convert to PSI divide by 2.31

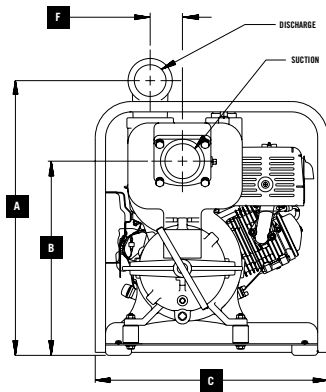

MODEL: 13A52-GX390

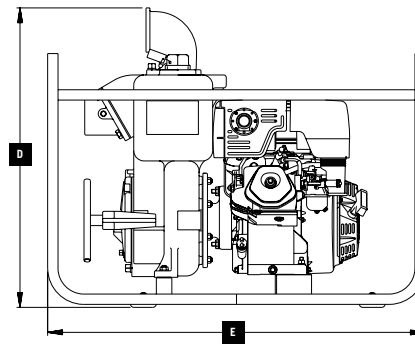

INCHES
(MILLIMETERS)

PUMP DIMENSIONAL DATA

Model	A	B	C	D	E	F	Suction*	Discharge*
13A52-GX390	26.56 (674,60)	18.78 (477,00)	22.50 (571,50)	28.95 (735,30)	36.50 (927,10)	3.12 (79,20)	3.00	3.00
13D1-GX270	21.50 (546,20)	13.62 (345,90)	20.00 (480,10)	23.62 (599,90)	28.00 (711,20)	00.00 (000,00)	3.00	3.00
13D-GX270	21.50 (546,20)	13.62 (345,90)	20.00 (480,10)	23.62 (599,90)	28.00 (711,20)	00.00 (000,00)	3.00	3.00
13D1-L70EE	22.28 (565,90)	14.44 (366,80)	21.00 (533,40)	24.40 (620,00)	28.00 (711,20)	00.00 (000,00)	3.00	3.00
13D-L70EE	22.28 (565,90)	14.44 (366,80)	21.00 (533,40)	24.40 (620,00)	28.00 (711,20)	00.00 (000,00)	3.00	3.00
13D1-L70EE S/G	22.28 (565,90)	14.44 (366,80)	21.00 (533,40)	24.40 (620,00)	28.00 (711,20)	00.00 (000,00)	3.00	3.00
13D-L70EE S/G	22.28 (565,90)	14.44 (366,80)	21.00 (533,40)	24.40 (620,00)	28.00 (711,20)	00.00 (000,00)	3.00	3.00
13E2-12LD477 S/G	28.55 (725,17)	20.30 (515,62)	30.26 (768,60)	30.69 (779,93)	43.00 (1092,20)	00.00 (000,00)	3.00	3.00
13E52-GX390	25.86 (656,84)	17.44 (442,98)	22.50 (571,50)	28.00 (711,20)	36.50 (927,10)	00.00 (000,00)	3.00	3.00
13G1-GX160	15.10 (383,54)	7.40 (187,96)	18.00 (457,00)	18.75 (476,00)	24.00 (610,00)	00.00 (000,00)	3.00	3.00
13G1-1B20	15.60 (396,24)	7.90 (200,66)	18.00 (457,00)	18.75 (476,00)	24.00 (610,00)	00.00 (000,00)	3.00	3.00

*Standard NPT Pipe Threads



DJ Gongol & Associates, Inc.
4801 Pommel Place
West Des Moines, IA 50265-2938
515-223-4144
sales@gongol.net

©2011 The Gorman-Rupp Company. The Gorman-Rupp Company reserves the right to discontinue any model or change specifications at any time without incurring any obligation.

O05-0010